

Retail

Accessories

TOPIKA d.o.o.

+386 41 696 270

info@topika.si

www.topika.si



Era 2.0
Armonia
Cub.8
Pegaso
Pegaso Maxi
Pegaso W
Albero legno

Display
PROMO





ideas



projects



production

ERA 2.0

Banco esposizione componibile

UNO SPAZIO VERSATILE
A very useful space



Era 2.0  

ERA 2.0

BANCO ESPOSIZIONE componibile

DESCRIZIONE	Struttura in tubolare metallico verniciato Ripiani in nobilitato, archetti di contenimento in metallo verniciato
ESPOSIZIONE	Varia, in base al numero di moduli impiegati
MOBILITÀ	Quattro ruote piroettanti di cui due con freno
EXTRA	Gancio con cesta in vimini
FINITURE	Grigio antracite opaco antigraffio, varie essenze di nobilitato

ERA 2.0

MODULAR DISPLAY COUNTER

DESCRIPTION	Painted metal frame in tubular section, shelves in manufactured wood, containment arches in painted metal
DISPLAY	Different display capacity according to the composition
MOBILITY	Four caster wheels, two of which lockable
EXTRA	Hook with wicker basket
FINISH	Anthracite grey anti-scratch coating, selection of wood finishes



ERA 2.0

Modular display counter

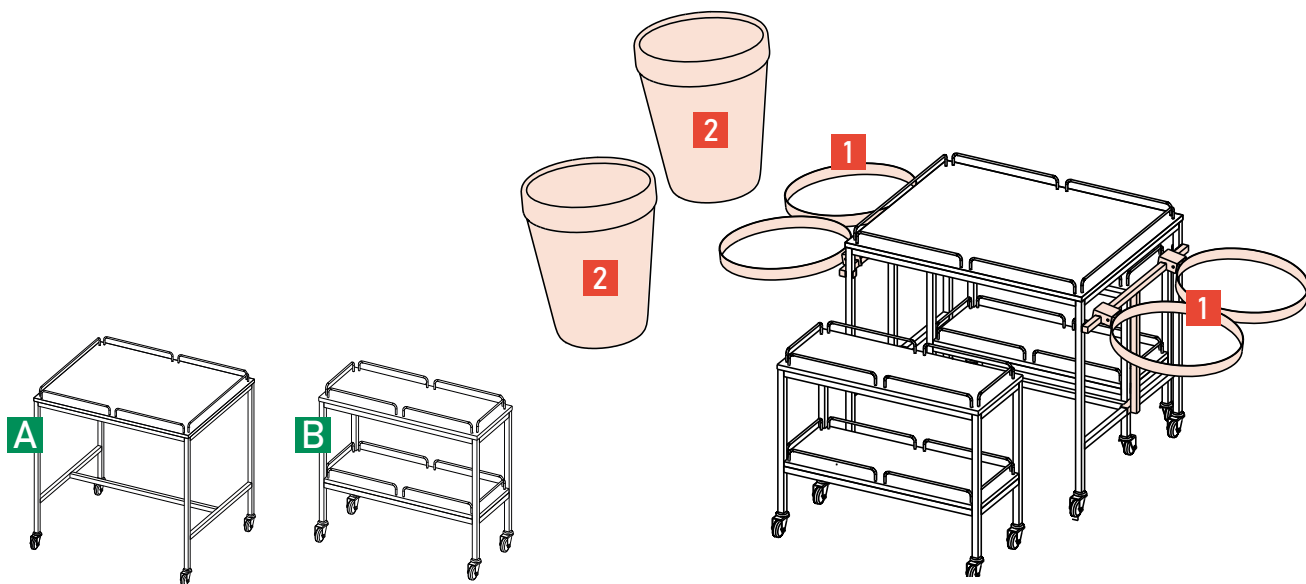

modello base / basic model

espositore completo di accessori / full optional display

	CODICE ORDER CODE	DESCRIZIONE DESCRIPTION	DIMENSIONI / DIMENSIONS				FINITURE / FINISHES	
			L mm	P mm	H mm	Ø mm		
A	PH.N0.180	Banco base su ruote in metallo verniciato, top in nobilitato. Wheeled base counter in painted steel, top in manufactured wood.	1000	800	1000	-	GA	•
B	PH.N0.085	Banco su ruote in metallo verniciato, due piani in nobilitato. Wheeled counter in painted steel, 2 levels in manufactured wood.	850	350	800	-	GA	•
1	PH.V0.181	Doppio supporto in metallo verniciato per ceste in vimini. Double painted metal support for wicker baskets.	440	798	-	-	GA	-
2	E504560.WI.000	Cesta in vimini compatibile con supporto in metallo. Wicker basket compatible with metal support.	-	-	600	500/ 450	-	-



FINITURE FINISHES

STRUTTURA STRUCTURE	LEGNO NOBILITATO VARIANTI WOOD FINISH SELECTION	"FINITURE" a pagina 78									
GA RAL 7016 Grigio antracite Anthracite grey	RC	PR	RN	OLI	RB	ABI	RM	NVL	NO	GA	GT

ARMONIA

Banco esposizione componibile

UNO SPAZIO VERSATILE
A very useful space



ARMONIA

BANCO ESPOSIZIONE

DESCRIZIONE	Struttura in tubolare metallico verniciato Ripiani in nobilitato
ESPOSIZIONE	Fino a cinque piani: fissi ed un piano intermedio regolabile in altezza
MOBILITÀ	Quattro ruote piroettanti di cui due con freno
EXTRA	Archetti di contenimento in metallo verniciato
FINITURE	Grigio antracite opaco antigraffio, varie essenze di nobilitato

ARMONIA

DISPLAY COUNTER

DESCRIPTION	Painted metal frame in tubular section, shelves in manufactured wood
DISPLAY	Five shelves, four of which fixed and the middle level adjustable in height
MOBILITY	Four caster wheels, two of which lockable
EXTRA	Containment arches in painted metal
FINISH	Anthracite grey anti-scratch coating, selection of wood finishes



Armonia RN

Versatile e d'impatto
la struttura di Chameleon arricchisce l'ambiente
e si amalgama perfettamente con il suo stile

ARMONIA

Modular display counter

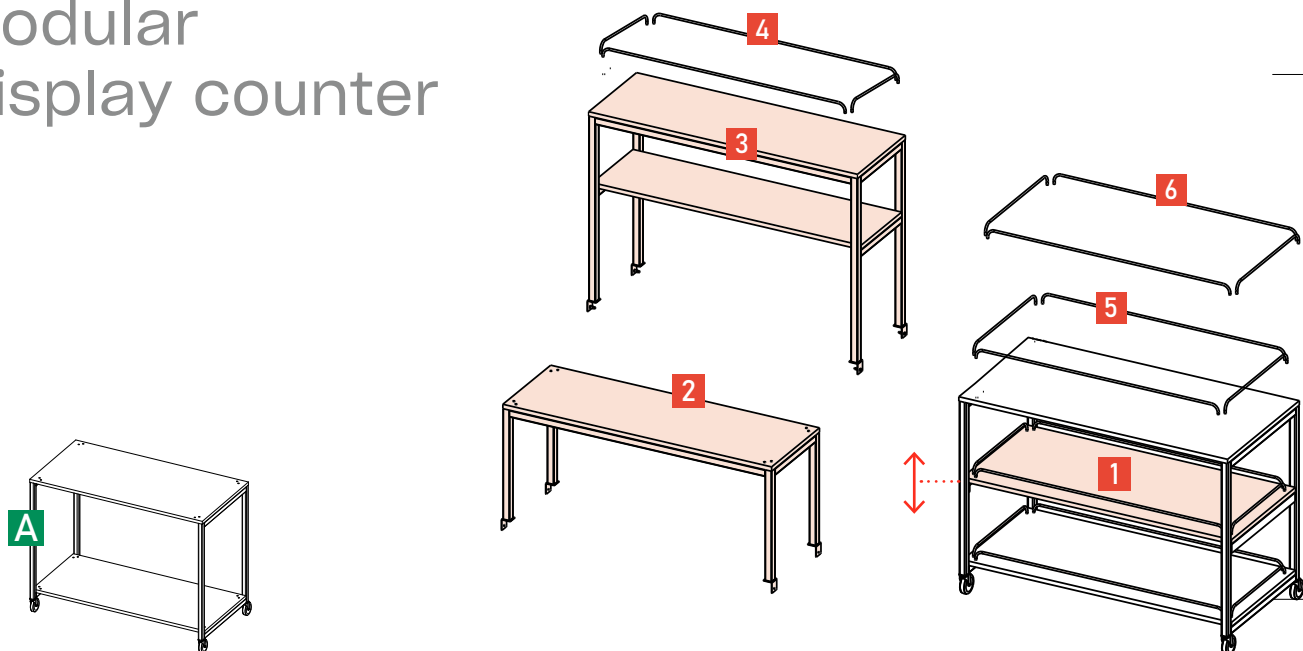

modello base / basic model

espositore completo di accessori / full optional display

	CODICE ORDER CODE	DESCRIZIONE DESCRIPTION	DIMENSIONI / DIMENSIONS				FINITURE / FINISHES	
			L mm	P mm	H mm	Ø mm		
A	PHRM.N0.200B	Banco base su ruote in metallo verniciato, due piani in nobilitato. Wheeled base counter in painted steel, 2 levels in manufactured wood.	1200	600	860	-	GA	•
1	PHRM.N0.121	Kit ripiano centrale regolabile in altezza in legno nobilitato. Middle level kit adjustable in height in manufactured wood.	1200	535	19	-	GA	•
2	PH.N0.200S	Modulo superiore ad 1 livello in metallo verniciato e piano in nobilitato. 1 level upper module in painted steel and manufactured wood shelf.	1200	400	545	-	GA	•
3	PH.N0.300S	Modulo superiore a 2 livelli in metallo verniciato e piani in nobilitato. 2 level upper module in painted steel and manufactured wood shelves.	1200	400	820	-	GA	•
4	PH.V0.106	Kit 4 archetti in metallo verniciato, per Armonia modulo superiore. 4 arches kit in painted steel, for upper module Armonia.	-	-	-	8	GA	-
5	PH.V0.105	Kit 12 archetti in metallo verniciato, per Armonia base e ripiano centrale. 12 arches kit in painted steel, for Armonia base display with middle shelf	-	-	-	8	GA	-
6	PH.V0.100	Kit 16 archetti in metallo verniciato, per Armonia completo di accessori. 16 arches kit in painted steel, for Armonia full optional display.	-	-	-	8	GA	-

Armonia cresce
insieme alle vostre esigenze

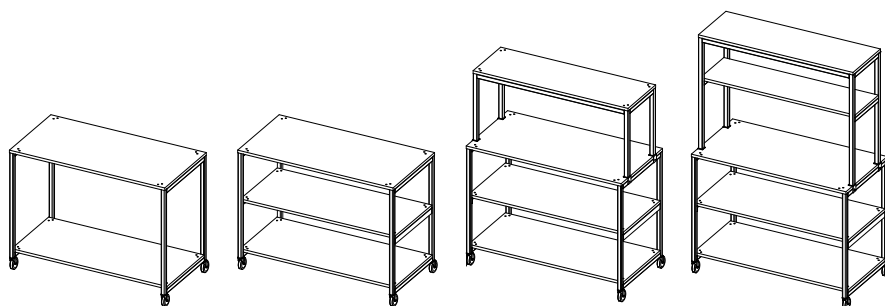

FINITURE FINISHES

STRUTTURA STRUCTURE	LEGNO NOBILITATO VARIANTI WOOD FINISH SELECTION	"FINITURE" a pagina 78									
RAL 7016 Grigio antracite GA Anthracite grey											

CUB.8

Banco esposizione

UNO SPAZIO VERSATILE
A very useful space



Cub.8  RN

CUB.8



BANCO ESPOSIZIONE

DESCRIZIONE	Struttura in tubolare metallico verniciato Ripiani e tamponature in nobilitato. Archetti di contenimento in metallo verniciato
ESPOSIZIONE	2 livelli fissi
MOBILITÀ	Statica
FINITURE	Grigio antracite opaco antigraffio, varie essenze di nobilitato

CUB.8







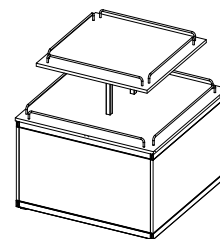





DISPLAY COUNTER

DESCRIPTION	Painted metal frame in tubular section, manufactured wood paneling. Containment arches in painted metal
DISPLAY	2 fixed levels
MOBILITY	Static
FINISH	Anthracite grey anti-scratch coating, selection of wood finishes

CODICE ORDER CODE	DIMENSIONI / DIMENSIONS				FINITURE / FINISHES	
	L mm	P mm	H mm	Ø mm		
EP8 .N0. 060	1000	1000	1115	-	GA	•



FINITURE FINISHES

STRUTTURA STRUCTURE	LEGNO NOBILITATO VARIANTI WOOD FINISH SELECTION	 "FINITURE" a pagina 78									
 GA RAL 7016 Grigio antracite Anthracite grey	 RC	 PR	 RN	 OLI	 RB	 ABI	 RM	 NVL	 NO	 GA	 GT

CUB.8

Display counter



from idea to reality

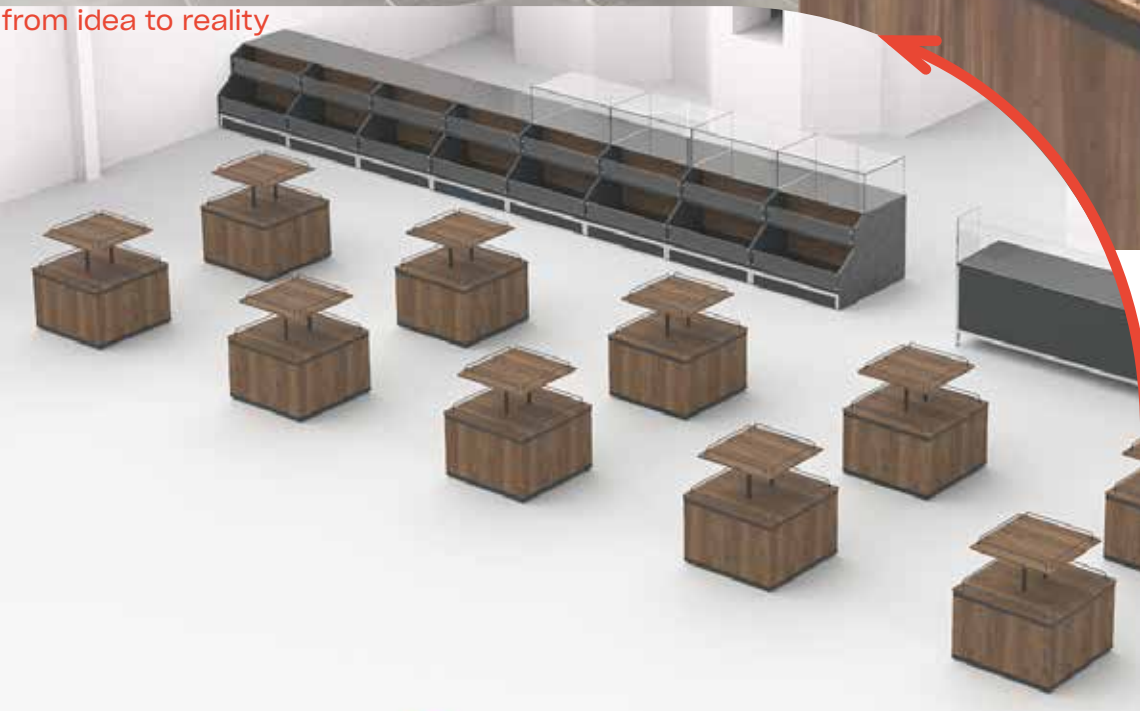

da idea
a realtà

PEGASO

Espositore promozionale componibile

SFOGGIARE
Show off!



PEGASO

BANCO ESPOSITORE COMPONIBILE

DESCRIZIONE	Gambe in tubolare quadro e ripiani in lamiera di metallo verniciato senza spigoli vivi. Spondine di contenimento removibili in lamiera sagomata a laser
ESPOSIZIONE	Varia in base al numero di moduli impiegati
MOBILITÀ	Statica
FINITURE	Grigio antracite anti graffio, sponde grigio chiaro

PEGASO

MODULAR DISPLAY COUNTER

DESCRIPTION	Legs in square section tubing and shelves in painted metal sheet. Removable containment sides in laser-shaped sheet metal
DISPLAY	Different display capacity according to the composition
MOBILITY	Static
FINISH	Anthracite grey and light grey

PEGASO

Modular promotional display

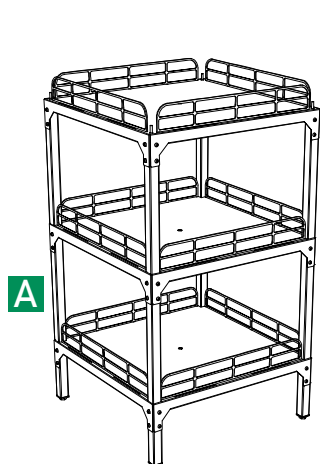

Composizione standard /
Standard composition

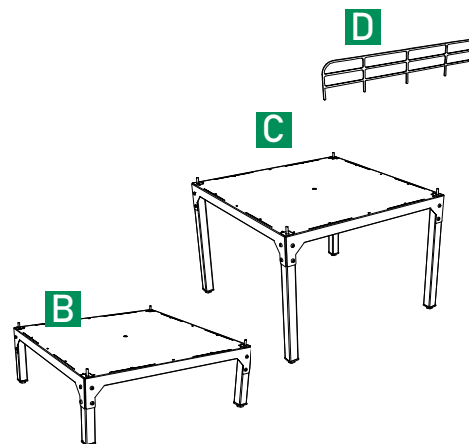

Singoli elementi per composizione personalizzata /
Single modules for customized composition

	CODICE ORDER CODE	DESCRIZIONE DESCRIPTION	DIMENSIONI / DIMENSIONS				FINITURE / FINISHES	
			L mm	P mm	H mm	Ø mm		
A	PH .V0. 002	Composizione standard 3 piani con spondine, in metallo verniciato. Standard composition: 3 levels with containment sides in painted steel.	600	600	1100	-	GA	-
B	PH .V0. 002-1	Modulo base con gambe, in metallo verniciato. Base module in painted steel.	600	600	200	-	GA	-
C	PH V0. 002-2	Modulo piano intermedio / superiore, in metallo verniciato. Middle / upper module in painted steel.	600	600	400	-	GA	-
D	PH .V0. 026	Spondina di contenimento removibile in lamiera taglio laser verniciata. Removable containment side in painted laser-shaped sheet steel.	496	3	110	-	GT	-



FINITURE FINISHES

STRUTTURA STRUCTURE		ACCESSORI ACCESSORIES	
	RAL 7016 Grigio antracite GA Anthracite grey		RAL 9006 Grigio chiaro GT Light grey

PEGASO MAXI

Espositore promozionale 5 livelli

5 levels promotional display unit

SFOGGIARE

Show off!

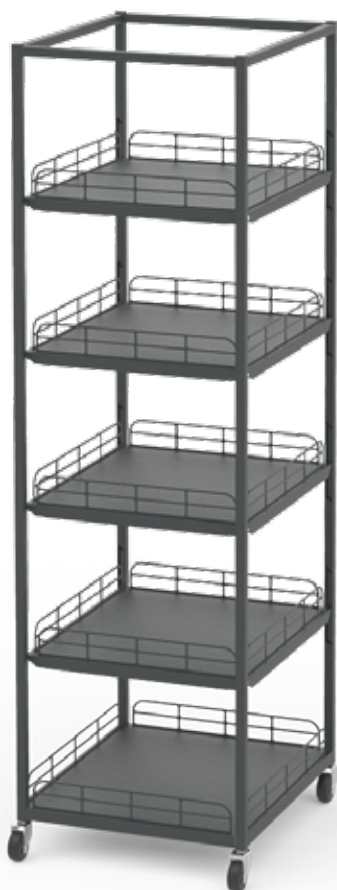

PEGASO MAXI

ESPOSITORE PROMOZIONALE 5 LIVELLI

DOTAZIONE BASE

DESCRIZIONE	Telaio in tubolare quadro e ripiani in lamiera di metallo verniciato. Spondine di contenimento removibili in lamiera sagomata a laser.
ESPOSIZIONE	4 ripiani inclinabili e regolabili in altezza, 1 ripiano base fisso
MOBILITÀ	Quattro ruote piroettanti in gomma di cui due con freno
FINITURE	Grigio antracite opaco antigraffio



PEGASO MAXI

5 LEVELS PROMOTIONAL DISPLAY UNIT

BASIC EQUIPMENT

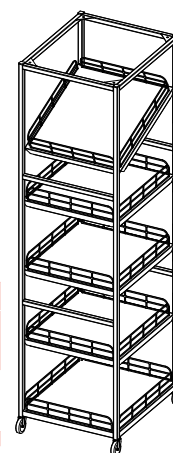
DESCRIPTION	Square-section tubing with no sharp edges in painted steel, removable side rails
DISPLAY	4 adjustable tilting shelves, 1 lower fixed shelf
MOBILITY	4 caster rubber wheels 2 of which lockable
FINISH	Anthracite grey anti-scratch coating



CODICE ORDER CODE	DIMENSIONI / DIMENSIONS				FINITURE / FINISHES	
	L mm	P mm	H mm	Ø mm		
PH .V0. 003	700	600	2090	-	GA	-

FINITURE FINISHES

STRUTTURA STRUCTURE				
 RAL 7016 Grigio antracite GA Anthracite grey				

PEGASO W

Espositore promozionale 5 livelli

5 levels promotional display unit

SFOGGIARE

Show off!



PEGASO W

ESPOSITORE PROMOZIONALE 5+1 LIVELLI

DOTAZIONE BASE

DESCRIZIONE	Telaio centrale in tubolare e 5 ripiani ottagonali in lamiera di metallo verniciato. Spondine di contenimento in lamiera.
ESPOSIZIONE	4 ripiani regolabili in altezza, 1 ripiano base fisso. 1 ripiano aggiuntivo opzionale.
MOBILITÀ	Statica
FINITURE	Grigio antracite opaco antigraffio

PEGASO W

5+1 LEVELS PROMOTIONAL DISPLAY UNIT

BASIC EQUIPMENT

DESCRIPTION	Central tubing with no sharp edges in steel painted, 5 octagonal shelves in painted metal sheet. Sheet metal containment sides.
DISPLAY	4 height-adjustable shelves, 1 fixed base shelf. 1 optional additional shelf.
MOBILITY	Static
FINISH	Anthracite grey anti-scratch coating

CODICE ORDER CODE	DIMENSIONI / DIMENSIONS				FINITURE / FINISHES	
	L mm	P mm	H mm	Ø mm		
PH .V0. 060	700	700	1600	-	GA	-
1 PH .V0. 062	505	505	1,5	-	GA	-
2 EDS2 .P0. 011	306	10	216	-	-	-



FINITURE FINISHES

STRUTTURA STRUCTURE						
	RAL 7016 Grigio antracite					
GA	Anthracite grey					

ALBERO LEGNO

Espositore con ceste in legno



ALBERO LEGNO

ESPOSITORE MULTIFACCIALE CARRELLATO

DOTAZIONE BASE

- DESCRIZIONE** Struttura in acciaio INOX
- ESPOSIZIONE** Otto piani inclinati ciascuno con un cestino in legno naturale dim. mm 250 x 400 H150
- MOBILITÀ** Quattro ruote piroettanti in gomma di cui due con freno
- FINITURE** Acciaio INOX, betulla naturale

WOODEN BASKETS TREE

WHELLED DISPLAY UNIT



BASIC EQUIPMENT

- DESCRIPTION** Structure in stainless steel
- DISPLAY** Eight inclined levels with 8 baskets dim. mm 250 x 400 x 150
- MOBILITY** Four caster wheels, two of which lockable
- FINISH** Stainless steel, natural birch

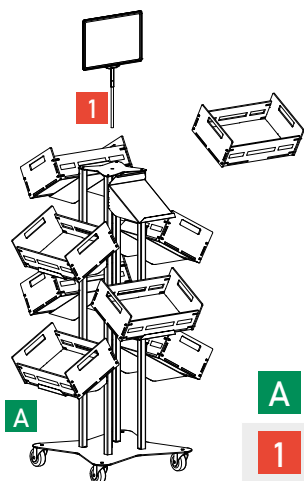

Interessato solo ai cestini smontabili?
Dim.250x400x150 mm
Codice: **EP5.W3.008**



	DIMENSIONI / DIMENSIONS				FINITURE / FINISHES		CODICE ORDER CODE
	L mm	P mm	H mm	Nr.  250 x 400 x H150			
A	760	760	1370	8	IO	-	EP5 .IO. 100
1	306	10	216	-	-	-	EDS2 .PO. 011

FINITURE FINISHES

STRUTTURA STRUCTURE	
 IO Acciaio INOX Stainless steel	 LB CESTE Betulla naturale Natural birch baskets

ALBERO VIMINI

Espositore con ceste in vimini



ALBERO VIMINI

ESPOSITORE MULTIFACCIALE

DOTAZIONE BASE

DESCRIZIONE	Struttura in acciaio INOX
ESPOSIZIONE	Quattro anelli in acciaio con quattro cestini in vimini intrecciato tonde, dim. mm 370 x 370 x H160
MOBILITÀ	Statica
FINITURE	Acciaio INOX, vimini naturale

WICKER BASKETS TREE

DISPLAY UNIT

BASIC EQUIPMENT

DESCRIPTION	Structure in stainless steel
DISPLAY	Four stainless steel ring supporting wicker baskets dim. mm 370 x 370 x 160
MOBILITY	Static
FINISH	Stainless steel, natural wicker



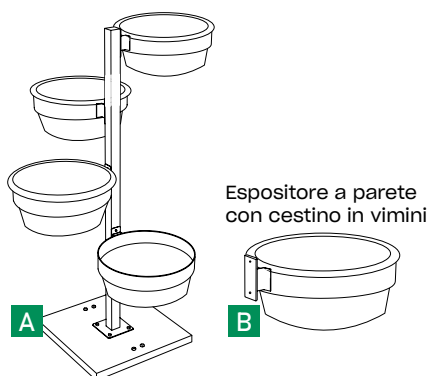

Interessato solo ai cestini?
Dim.370x370x160 mm
Codice: **E373716.W1.000**



	DIMENSIONI / DIMENSIONS				FINITURE / FINISHES		CODICE ORDER CODE
	L mm	P mm	H mm	Nr.  370 x 370 x H160			
A	820	820	1250	4	IO	-	EP5 .I0. 120
B	370	370	160	1	IO	-	EP5 .I0. 037

FINITURE FINISHES

STRUTTURA STRUCTURE		
 Acciaio INOX Stainless steel	 ceste VIMINI NATURALE Natural wicker baskets	